

**ASSEMBLY INSTRUCTIONS**  
**RIO 4' BED**

**IMPORTANT: READ THESE INSTRUCTIONS CAREFULLY BEFORE ATTEMPTING TO ASSEMBLE OR USE YOUR RIO 4' BED FRAME**

**PLEASE KEEP THESE INSTRUCTIONS FOR FUTURE REFERENCE**

**HEALTH & SAFETY:**

DO NOT jump on this bed frame  
DO NOT use this bed frame if any parts are missing, damaged or worn  
DO NOT use this bed frame unless all fixings are secured  
Always use on a level, even surface

**WARNING: If this bed is placed on a laminated floor you must place some protection under all legs to stop the bed frame from moving. If this is not adhered to there is no guarantee if the bed frame collapses**





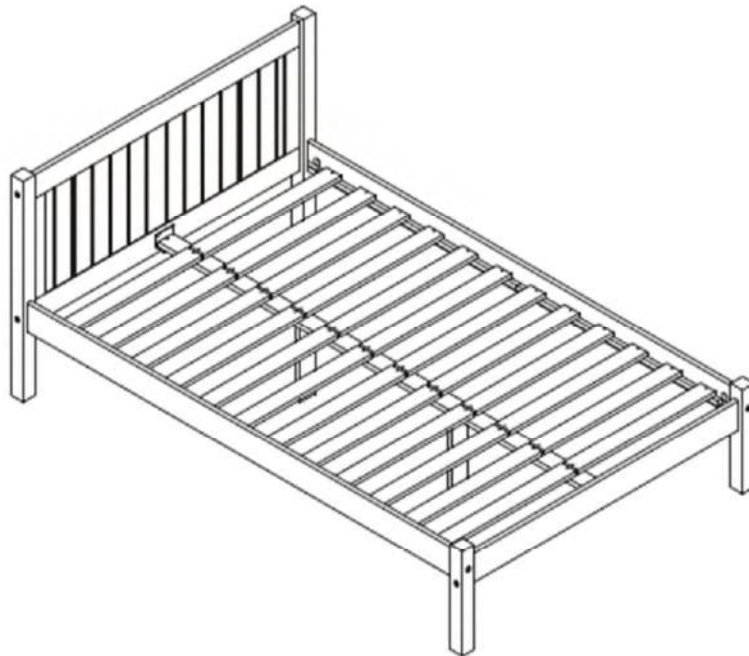



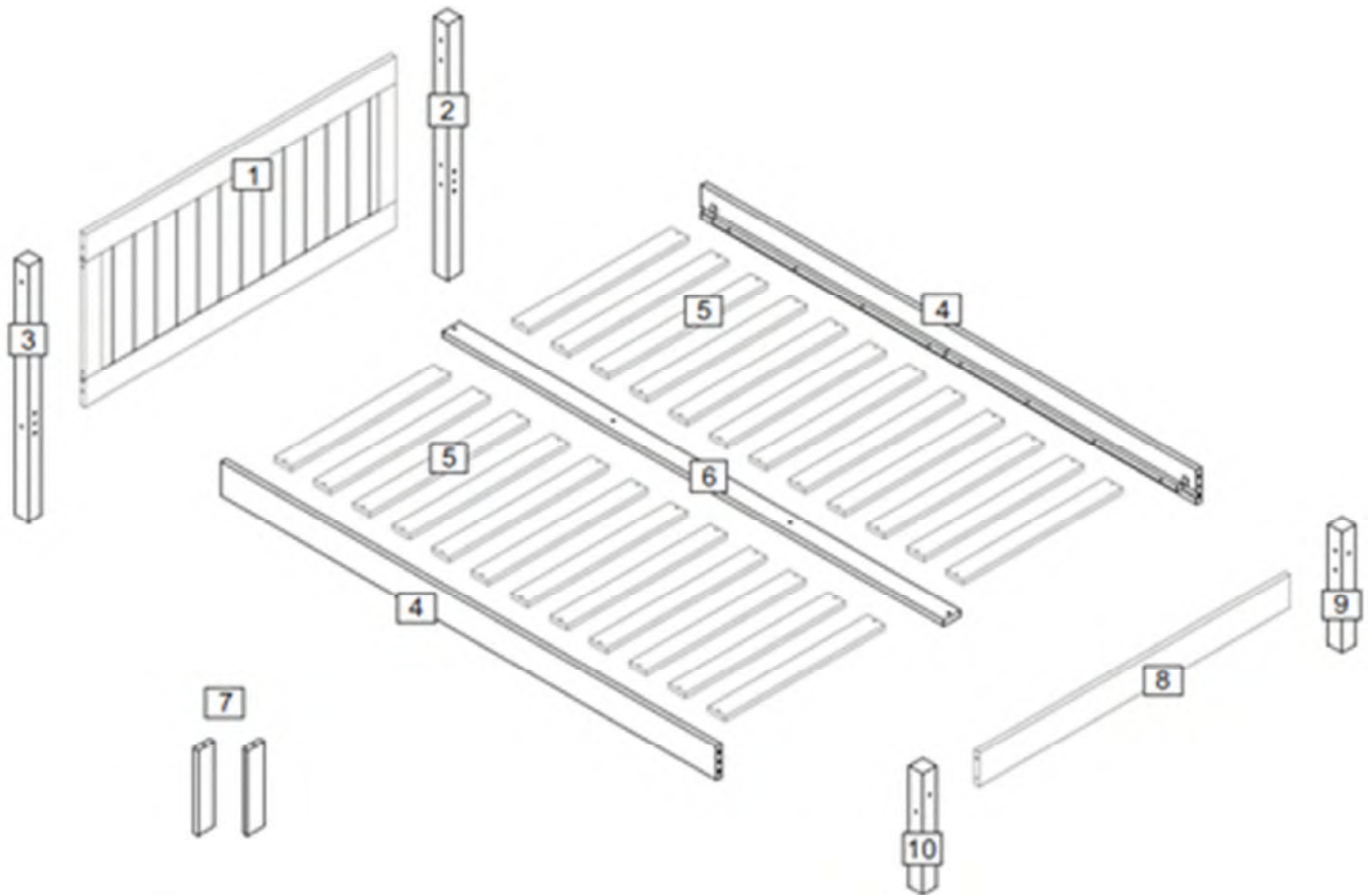

**CARE & MAINTENANCE:**

Periodically check all screws & fixings to ensure they are secure  
DO NOT push the bed frame as this will damage the legs  
Always lift the bed with two people to reposition  
Keep any sharp objects away from the frame

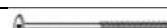
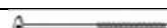

[www.birlea.com](http://www.birlea.com)



Parts List				Hardware List (found in box 1)		
Part	Description	Box	Qty	Part	Description	Qty
1	Headend Panel	1	1	A	30 mm Dowel 	6
2	Left Headend Post	3	1	B	40 mm Dowel 	8
3	Right Headend Post	3	1	C	16 mm Screw 	8
4	Side Rail	2	2	D	30 mm Screw 	48
5	Slat	1	24	E	32 mm Bolt 	2
6	Centre Rail	2	1	F	Nut 	2
7	Support Leg	1	2	G	50 mm Bolt 	2
8	Footend Panel	1	1	H	100 mm Bolt 	6
9	Left Footend Post	3	1	J	100 mm Bolt 	4
10	Right Footend Post	3	1	K	Elliptical Nut 	4
** You will need a screwdriver, M11 spanner and a small mallet (not provided)				L	Metal Bracket 	2
				M	Allen Key 	1
				N	Spacer 	2

Step 1: Attach the support legs (7) to the centre rail (6) using hardware parts G and M, then insert hardware part B to the side rails (4) using a small mallet (not provided).

DO NOT use any power tools as this may damage the frame and will invalidate any claim.

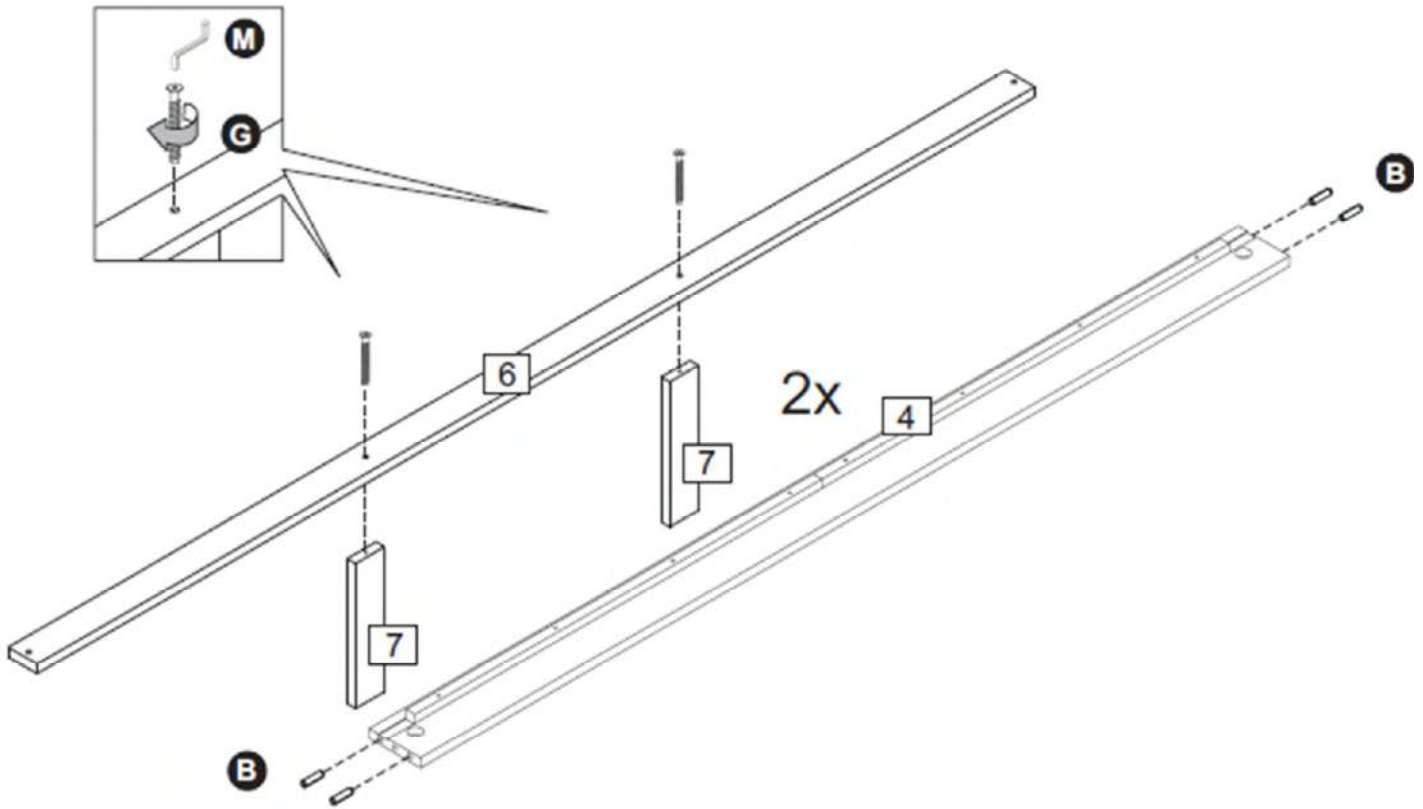

Step 2: Insert hardware part A to the headend panel (1) and footend panel (8) using a small mallet (not provided).

DO NOT use any power tools as this may damage the frame and will invalidate any claim.

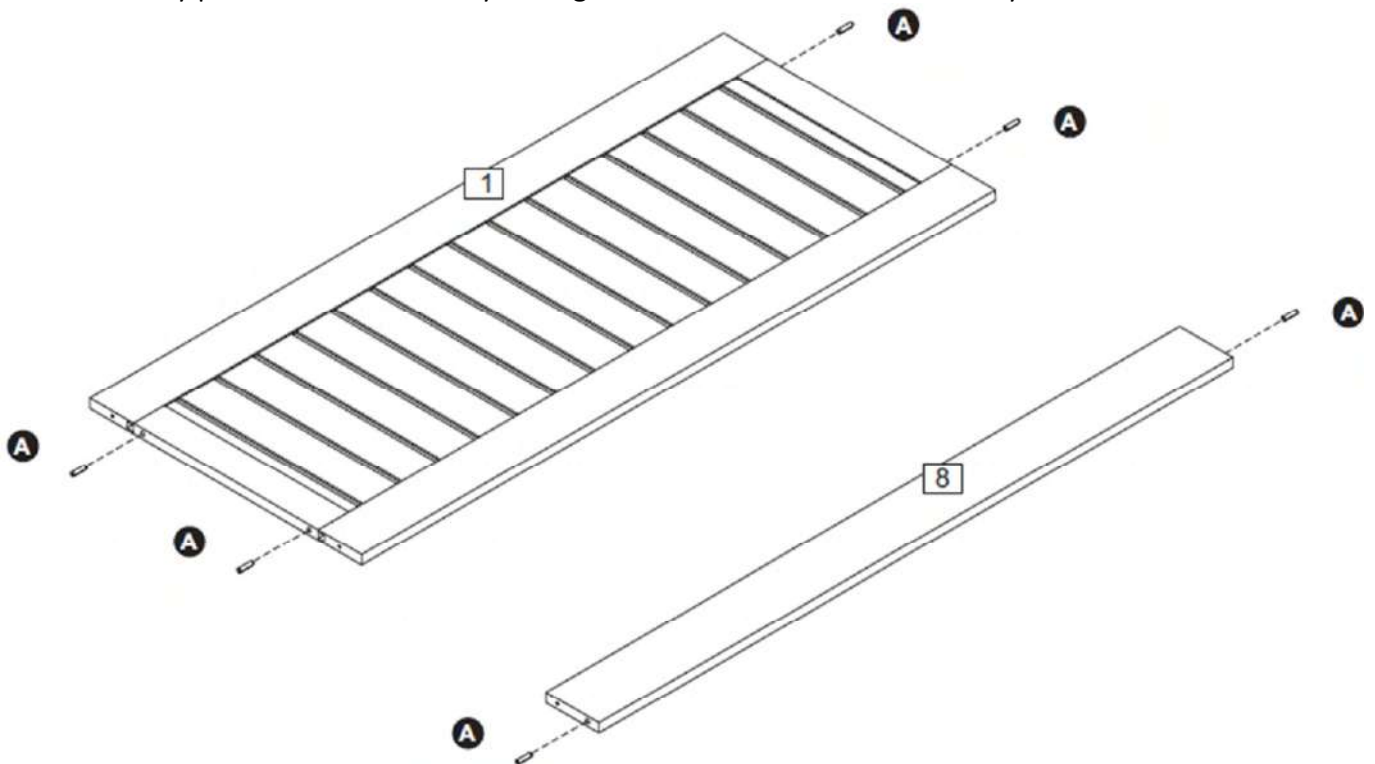

Step 3: Attach the left headend post (2) and right headend post (3) to the headend panel (1) using hardware parts H and M.

DO NOT use any power tools as this may damage the frame and will invalidate any claim.

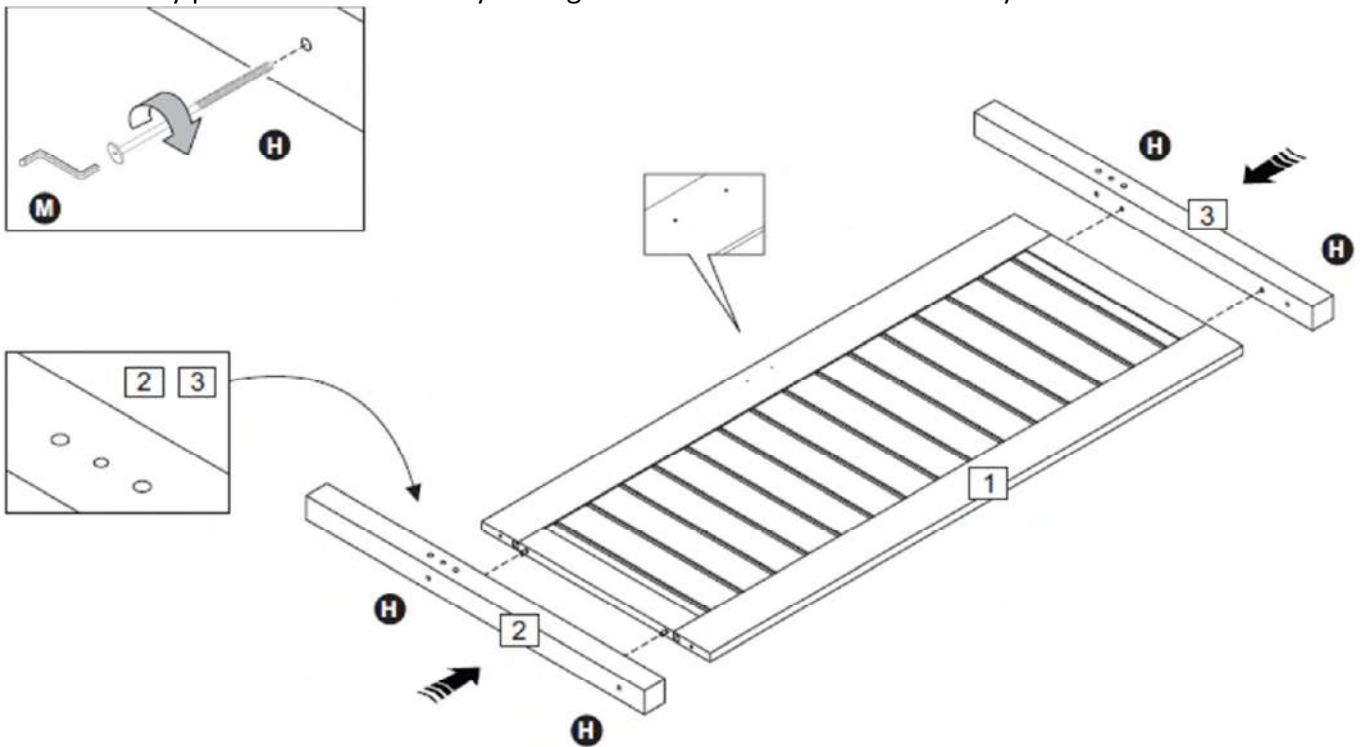

Step 4: Attach the left footend post (9) and right footend post (10) to the footend panel (8) using hardware parts H and M.

DO NOT use any power tools as this may damage the frame and will invalidate any claim.

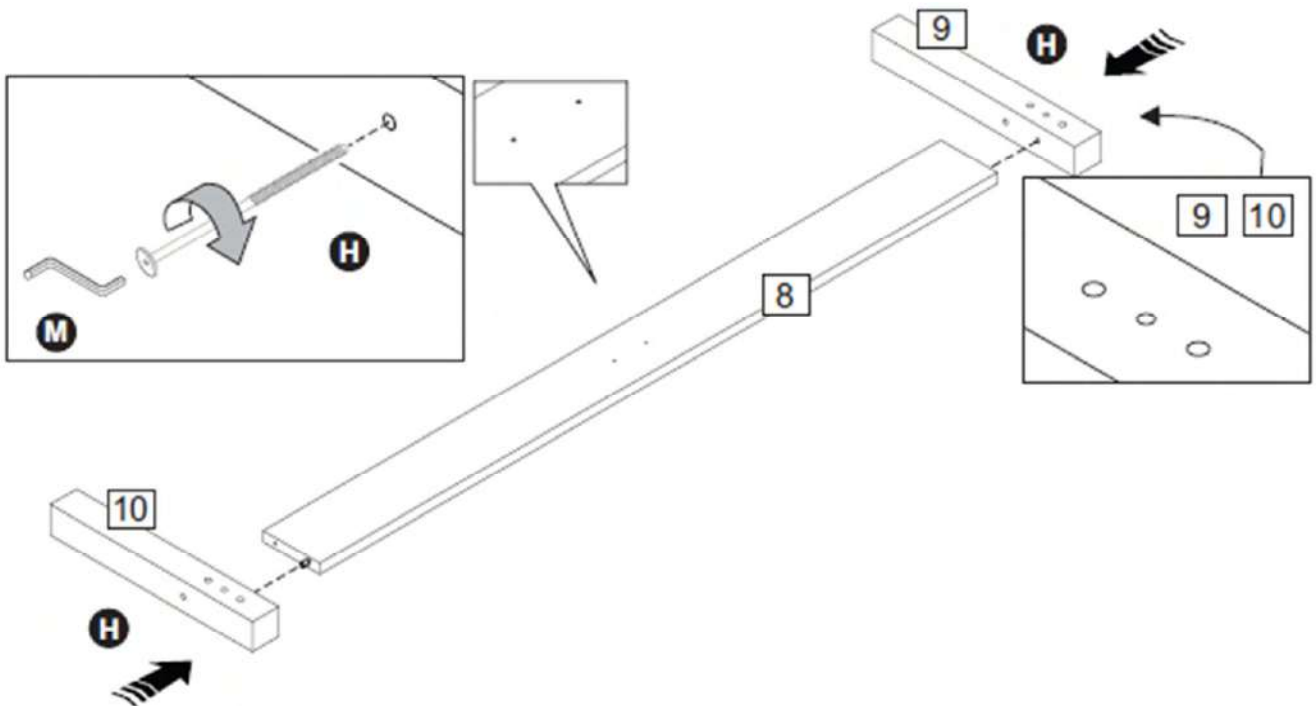

Step 5: Fix hardware part L to the headend panel (1) and footend panel (8) using hardware part C and a screwdriver (not provided)

DO NOT use any power tools as this may damage the frame and will invalidate any claim.

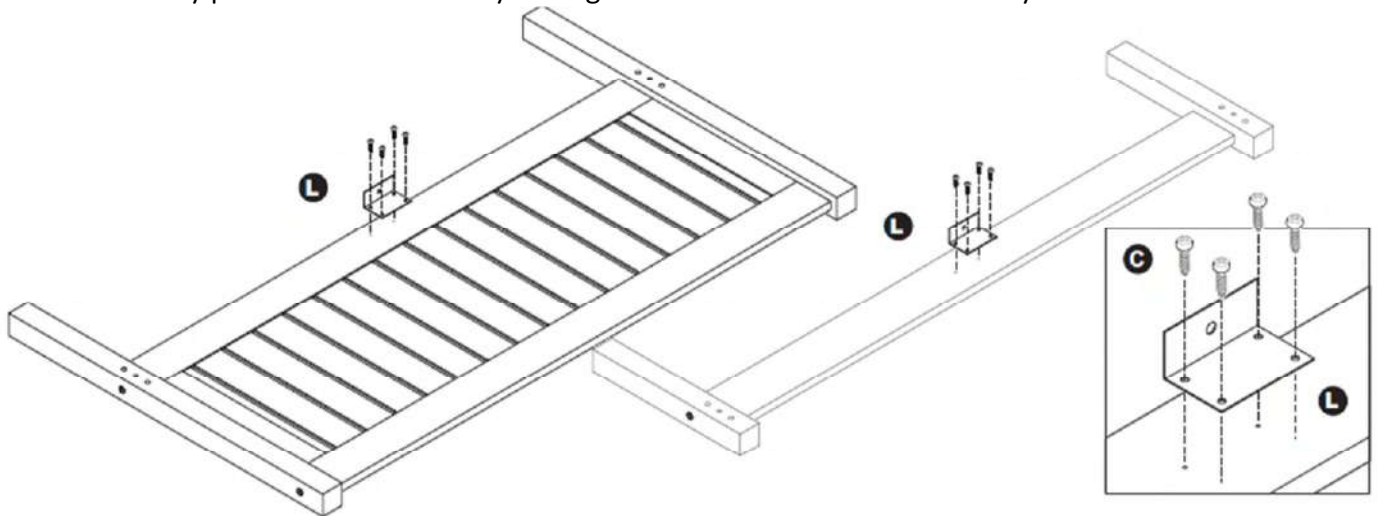

Step 6: Attach the side rails (4) to the headend posts using hardware parts J, K and M, then fix the centre rail (6) using hardware parts E and F and a spanner (not provided).

DO NOT use any power tools as this may damage the frame and will invalidate any claim.

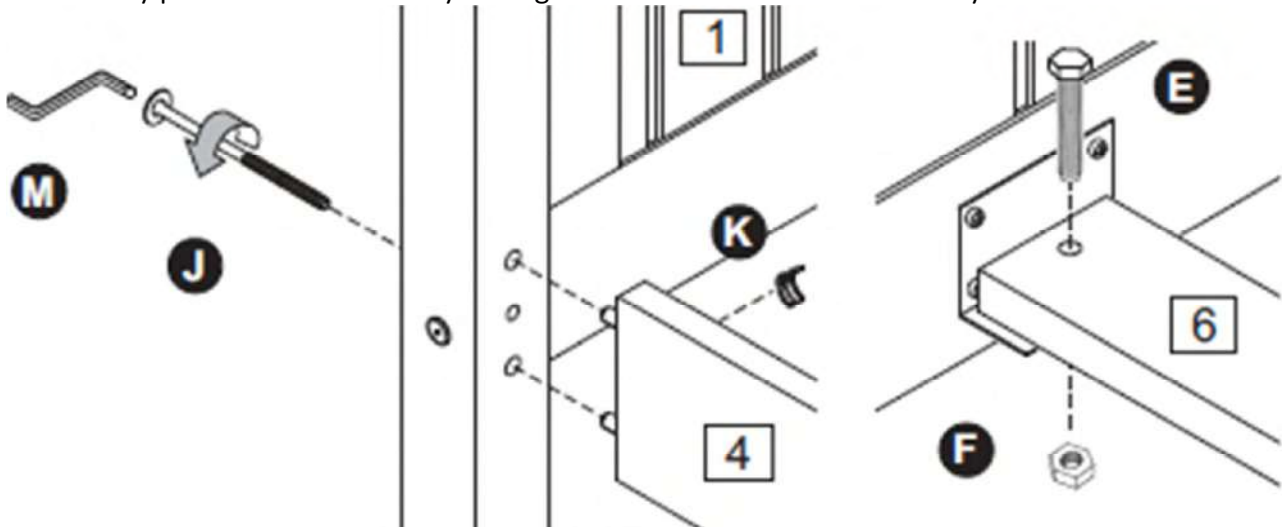

Step 7: Attach footend posts to side rails (8) using hardware parts J, K and M, then fix the centre rail (6) using hardware parts E and F with a spanner (not provided).

DO NOT use any power tools as this may damage the frame and will invalidate any claim.

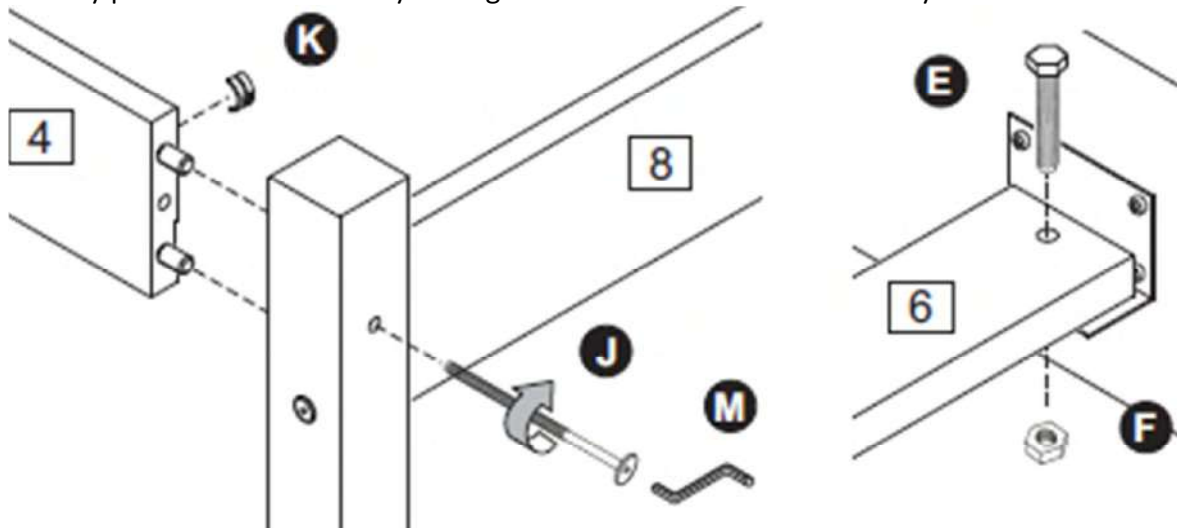

Step 8: Fix slats (5) to the side rails (4) and centre rail (6) using hardware parts N and D with a screwdriver (not provided). Make sure to start from the ends and work towards the middle.

DO NOT use any power tools as this may damage the frame and will invalidate any claim.

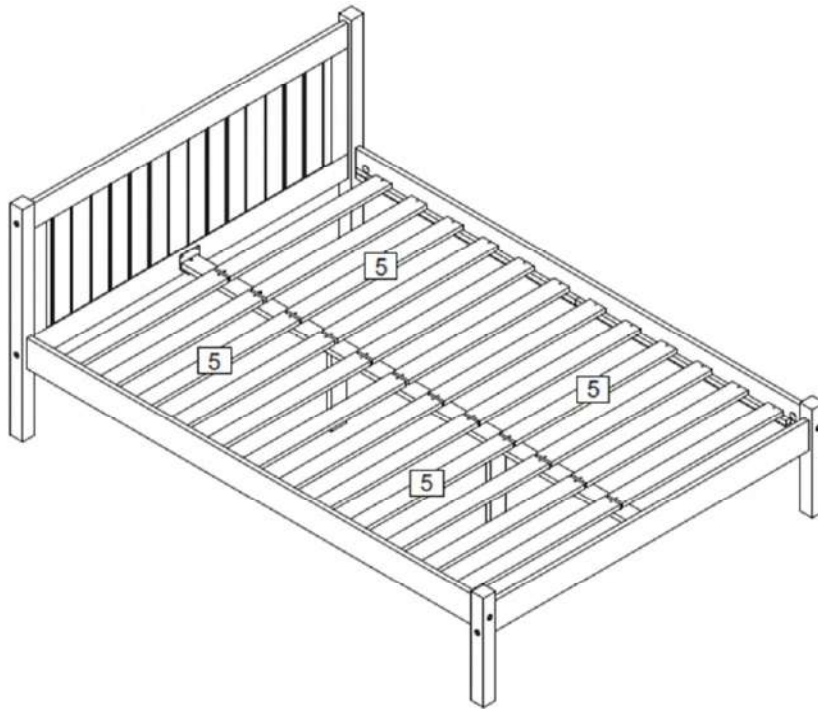

a:

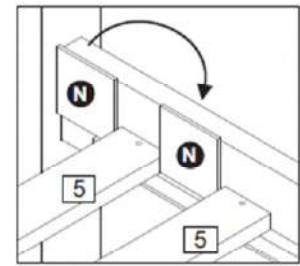

b:

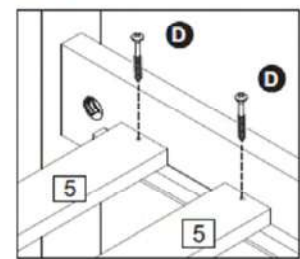

### Additional Information:

- For complete product information, images and dimension diagrams please visit the website [www.birlea.com](http://www.birlea.com)
- If you have any issues with your item please contact the retailer directly you purchased it from who will be able to resolve any issues with Birlea.
- Why don't you send us photos of your assembled furniture to [info@birlea.com](mailto:info@birlea.com) to be shared in our #birleahome feature on Instagram.